

Dimensions: mm (in.)

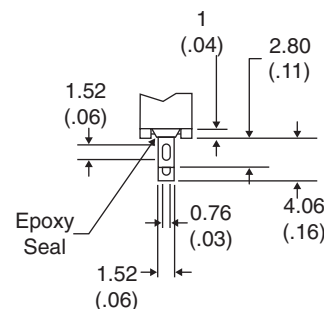
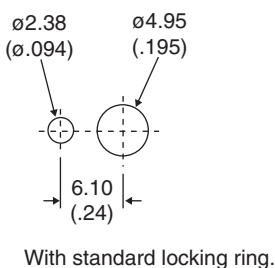
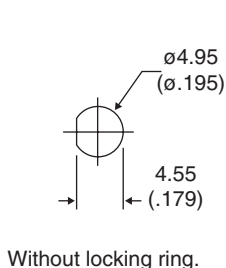
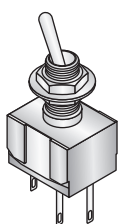
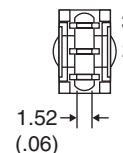
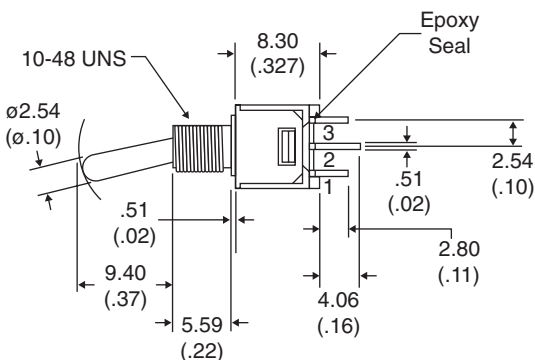
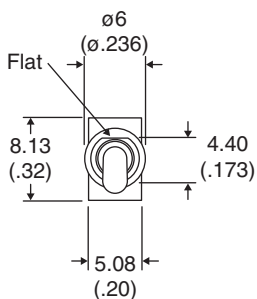

PANEL MOUNTING

SOLDER LUG

POS.1	POS.2
ON	ON
2-3	2-1

Electrical Specifications:

- Electrical Life: 30,000 make-and-break cycles at full load
- Contact Resistance: 20mΩ max. initial @ 2-4VDC 100mA
- Insulation Resistance: 1,000MΩ min.
- Dielectric Strength: 1,000 V RMS@ sea level.
- Rating:
 - 1A / 250 VAC
 - 3A / 120 VAC or 28 VDC

Mechanical Specifications:

- Operating Temperature: -30° C to +85° C

Materials:

- Case: Diallyl phthalate (DAP)
- Acuator: Brass, chrome plated.
- Bushing: Brass, nickel plated.
- Housing: Stainless steel.
- Switch Support: Brass, tin plated.
- Terminal/Contact: Brass, silver plated.

Note:

- RoHS compliant by exemption

Toggle Switch
108-2MS1T1B1M1QE-EVX

